

A Project-Oriented Integral Curriculum on Electronics for Telecommunication Engineers

F. Machado, N. Malpica, J. Vaquero, B. Arredondo, S. Borromeo

° Departamento de Tecnología Electrónica

Universidad Rey Juan Carlos

Móstoles, Madrid, Spain

{felipe.machado, norberto.malpica, joaquin.vaquero, belen.arredondo, susana.borromeo}@urjc.es

Abstract— This paper describes the Electronics curriculum in the Telecommunication Engineer degree at Rey Juan Carlos University (URJC) in Spain. Telecommunication Engineering started in the 2003-2004 academic year. In these years, all the electronic courses have been set up with a main practical orientation and with Project Based Learning (PBL) activities, both compulsory and voluntary. Once these courses have been successfully implemented we have reoriented some of the practical activities to be more interlaced. In this sense, projects involving students of different courses have been developed, as well as projects involving students from different years. All these activities fit in the principles promulgated by the Declaration of Bologna, which results in the actual updating of the university degree structure in Spain.

Keywords: *integral curriculum, Electronics, project-oriented, Bologna process*

I. INTRODUCTION

This paper describes the Electronics curriculum of the Telecommunication Engineer degree at Universidad Rey Juan Carlos (Spain). Telecommunication Engineering was established in the 2003-2004 academic year. In these years, all the electronic courses have been set up with a main practical orientation and with Project Based Learning (PBL) activities, both compulsory and voluntary. In addition, the electronic curriculum has been consistently defined considering the contents and the relationships among the courses. These courses have been successfully implemented [1], [2].

Project-based learning is an instructional method that challenges students to think critically and enhance their ability to analyze and solve real world problems, develop skill in gathering and evaluating the information needed for solving problems, gain experience working cooperatively in teams. Successful implementation of Project Based Learning (PBL) strategies has been well documented [3-5].

Moreover, the regulatory modifications promulgated by the Bologna Process results in the implementation of new university degrees structures in Spain [6] and the adoption of the European Credit Transfer and Accumulation System (ECTS) [7]. This process implies a shift from traditional teacher-centered to a learner-centered approach, thus new teaching methodologies have to be introduced that focus on a more active participation of students in their learning process.

In this context, we have reoriented some of the practical activities to be more interlaced. Projects within more than one course and activities among students of different courses have been developed. Moreover, projects to be executed in more than one academic year have been planned. The implemented curriculum structure and the new activities proposed, allow a seamless transition to the Bologna Process.

This paper is structured as follows; section 2 presents the electronics curriculum context and the relationship among different courses and a description of the details, methodology, contents, evaluation data and organization of every course. Section 3 describes the recently introduced PBL activities among different courses. Finally, the results are summarized and discussed, and the conclusions are presented.

II. ELECTRONICS CURRICULUM IN TELECOMMUNICATION

Prior to the implementation of the Bologna Process, the Telecommunication Engineering degree was structured in five years, each one having two semesters. Each semester has an average of 36 credits. Each credit is equivalent to 10 hours of lessons including lectures and labs. A final degree project has to be presented (9 credits). The aim of this project is to develop a supervised complete engineering project, as a first approach to the student's future professional activity. It is equivalent to a MSc. Thesis.

Figure 1 shows the courses related to Electronics in the Telecommunication degree. All these courses are compulsory and, except for those shaded, are taught by the department of Electronics. Therefore, we have been able to elaborate a complete and comprehensive Electronics curriculum with no overlapping contents.

As can be seen, the courses cover both digital and analogue electronics. Besides, there are some other courses very closely related to the electronics curriculum. Computer Fundamentals, taught in the second year (fig. 1), are a required background for following courses. There is also a course on Communication Terminals, given in the fifth year, focused on the terminals basic specifications and internal block architecture.

Even though it is not shown in fig. 1, it is worth noticing that second year students also attend Photonics, covering the basis aspects of optoelectronic devices (LEDs, Photodiodes, Lasers...). This subject together with AE, will serve as background for Optical Communications I and II, which will be taught in the fourth and fifth years respectively.

year - semester	Analogue Electronics	Digital Electronics	Computer Fundamentals
1-1	CAD (6 credits) Circuit analysis and design		
1-2	ECM (6cr.) Electronic Components and Measures	DE1 (4.5cr) Digital Electronics I	
2-1	AE (6cr.) Analogue Electronics	DE2 (4.5cr) Digital Electronics II	CF1(6cr.) Computer Fundamentals I
2-2			CF2 (6cr.) Computer Fundamentals II
3-1		DES (6cr) Digital Electronic Systems	
4-1		ESCD (6 cr.) Electronic Systems & Circuits Design	
4-2	EI (6 cr.) Electronic Instrumentation		
5	MSc Thesis (9 cr.)		

Figure 1: Electronic and related courses in the degree

On their fifth year, students who want to broaden their knowledge of electronics can work on their MSc. Thesis in our department.

Finally, it is also worth mentioning the approximate number of students attending electronic courses in each year. First year students attending ECM and EDI are around 150 divided in two groups, with one professor per group, and the support of another professor for laboratories. Second year students coursing AE and EDII are around 80 divided in two groups, with two professors both for theory and laboratory. Third year students coursing DES are approximately 60, with one professor for theory and two for the laboratory. Fourth year students coursing ESCD and EI are approximately 30, with one professor for theory and laboratory.

Following, a brief description of each course will be given.

A. Electronic Components and Measurements (ECM)

The Electronic Components and Measurements (ECM) course is a 6 credit second semester, first year compulsory course. ECM comprises theory (3 credits), practical exercises in class (1.5 credits) and practical work in the laboratory (1.5 credits). The essential background on circuit analysis is provided by the first semester, first year course on Circuit Analysis & Design (CAD) as can be seen in fig. 1. Therefore, students are familiar with linear circuit analysis with basic passive components, resistors, inductors and capacitors. On the other hand, this course provides the necessary knowledge on basic electronic components needed for the second year Analogue Electronics (AE) course.

According to the number of students and available laboratories, the students are divided in two groups for theoretical lectures and practical exercises classes and in three groups for laboratory work.

The aim of the ECM course is the learning of electronic fundamentals, including semiconductor principles and basic analogue circuits with individual components, and basic laboratory procedures, such as instrumentation use, measurements techniques and safety procedures. First, the Operational Amplifier is introduced, as a “black box”, in both linear and non-linear circuits. This allows the student to design fully functional basic circuits from the very beginning. Then, the principles of the rectifier and Zener diode and associated basic circuits are deeply studied, followed by other diode types (Schottky, LED, photodiode, tunnel) explanation. Finally, Bipolar and FET transistors are studied both following the same scheme; principles, models, DC analysis, applications and ideal-actual component comparison. The AC analysis is also explained as an introduction to AE course.

During theoretical lectures, multiple practical examples are used in the explanation. Practical exercises classes are reinforced with circuit simulations. Students have circuit simulation software available in free-access computer rooms. Laboratory work comprises a theoretical circuit to be studied analysis, circuit simulation, practical circuit implementation and critic practical-theoretical results comparison. This work is divided in five different guided sessions:

- Linear circuit analysis, where instrumentation use and measurement techniques are applied to simple linear circuit, so the student acquires the necessary skills
- Circuit simulation software, that will be used in the following sessions
- Operational Amplifier linear circuits implementation
- Basic rectifier diode circuits
- Bipolar transistor basic circuits.

The final mark is given by the exam mark weighted by 0.7 plus the laboratory mark weighted by 0.3. A minimum of 4 over 10 points are needed in the exam mark to pass the course. Laboratory work is evaluated in situ and, in addition, students must prepare a final report of each laboratory session.

B. Digital Electronics I (DEI)

The Digital Electronics I (DEI) course is a 4.5 credit second semester, first year compulsory course. DEI comprises theory (3 credits), practical exercises in class (0.5 credits) and practical work in the laboratory (1.0 credits). This is the first course on digital electronics in the degree, and provides the necessary knowledge on basic digital electronics needed for the second year Digital Electronics II (DEII) course, and for the higher level courses on electronic systems.

The aim of the course is to introduce the basic concepts in digital electronics, from numbering systems to simple sequential circuits. The following subjects are covered:

- Introduction to digital vs. analogue electronics. Review of sampling and quantification, advantages of electronics, brief history.
- Numbering systems and codes: Basic binary numbering systems (1's complement, 2's complement) and coding is presented. Binary arithmetics.
- Boolean algebra, logical functions and function simplification.
- Logical gates: Definition of the different logical gates, equivalences among them, and a short chapter on fabrication technologies and logical families.

The rest of the course deals is devoted to block design::

- Standard combinational blocks: review of the different blocks, practical designs using them. The chapter ends with the Arithmetic-Logic Unit, which serves as a review of the different block functions.
- Sequential circuits. Only biestables, registers and counters are studied, leaving more complicated designs for Digital Electronics II (DE2).

Students carry out two types of lab work. In the first session, they measure the features of several logical circuits and learn how to build simple circuits with discrete components. The second part of the course consists in designing and simulating circuits using schematics. We use the ISE-WebPack environment (Xilinx, San Jose, CA). Students are required to take three compulsory lab sessions and can also undertake several voluntary designs.

The final grade is given by the exam mark on top of which the laboratory mark is added (ranging from 0 to 1). A minimum of 4 over 10 points are needed in the exam mark to pass the course. Laboratory work is evaluated in situ and, in addition, students should send the project (schematics file) to be evaluated by the professor.

C. Digital Electronics II (DEII)

The digital electronic II (DE2) course is a 4.5 credit second year compulsory course. DE2 comprises theory (1.5 credits) and practical work in the laboratory (3 credits). Students taking this course have already a digital electronic background provided by the second semester, first year course on digital electronic I (DE1) where they have been taught the theoretical fundamentals of digital electronic design at logic level and logic-block level.

The aim of DE2 course is twofold: analyze and design sequential circuits and provide the necessary knowledge on the VHDL hardware description language. During the course, students will learn in depth digital design methodology. They will learn the methodology to design moderately complex digital circuits using finite state machines, computer-aided design (CAD) tools, VHDL and programmable logic devices (FPGAs). This course provides the necessary knowledge on digital design needed for the fourth year ESCD course.

The course takes place in a lab equipped for digital electronics. Designs are implemented in the Pegasus FPGA

Board (Digilent, Pullman, WA) using Xilinx ISE. In this course students learn the design methodology and the hardware description languages (VHDL) in a practical way. This practical work consists of ten lab sessions where several FPGAs based systems of incremental complexity are implemented. The sessions are structured as follows:

- Introduction to development environment: Pegasus FPGA board and Xilinx ISE.
- VHDL design: concurrent sentences and process. The purpose of this session is to design standard combinational blocks: multiplexers, code converter and 7-segment decoder.
- VHDL sequential circuits: flip-flops, counters and shift register.
- VHDL for simulation: design of testbenches.
- Design of system based on finite states machines: door lock, vending machine and controlling the speed of a DC motor circuit using PWM.

The final grade is given by the exam mark on top of which the laboratory mark is added (ranging from 0 to 1). A minimum of 4 over 10 points are needed in the exam mark to pass the course. Laboratory work is evaluated in situ and, in addition, students should send the project (VHDL code) to be evaluated by professor.

D. Analogue Electronics (AE)

The analogue electronic (AE) course is a 6 credit second year compulsory course. AE comprises theory (4.5 credits) and practical work in the laboratory (1.5 credits). Students taking this course have already an analogue electronic background provided by two different first year courses (Circuit Analysis & Design (CAD), and Electronic Components and Measurements (ECM)) as can be seen in fig. 1. Therefore, students coursing AE possess significant knowledge of circuit analysis techniques, and deep understanding of simple analogue circuits with individual components.

The main aim of the AE course is to analyze and design fairly complicated amplifier circuits based on single components. First, standard parameters such as gain, input and output impedance of typical amplifier configurations using Bipolar and FET transistors are studied. This is followed by a deep analysis of frequency response and typical feedback networks. Finally, the course ends up with a quick review of power stage amplifiers.

During theoretical lectures, multiple practical examples are introduced in the explanation. Besides, in order to pass the course, students are obliged to attend practical work in the laboratory. This practical work consists of six guided sessions in the laboratory. Three different experimental setups are proposed, corresponding to the design and analysis of different amplifiers:

- Design and analysis of a voltage amplifier
- Design and analysis of a current amplifier

- Analysis of a multiple-stage amplifier (power amplifier).

Students are evaluated in situ in the laboratory and, in addition, they will hand in a final report of the laboratory work. Those with a good laboratory work can raise the exam mark up to one point (provided they obtained a minimum of 4 over 10 in the exam). Thus, the final grade is given by the exam mark on top of which the laboratory mark is added (ranging from 0 to 1).

E. Digital Electronic Systems (DES)

The Digital Electronic Systems (DES) course is a 6 credit third year compulsory course. DES comprises theory (3.0 credits) and practical work in the laboratory (3.0 credits). Students taking this course have already a background on digital electronics provided by two first and second year courses (Digital Electronics I and II), and knowledge of microprocessor architecture and assembler language, provided by Computer Fundamentals I and II, as can be seen in fig. 1.

The aim of the course is to learn how to design simple embedded systems based on microcontrollers. Students learn microcontroller architecture in detail as well as A/D conversion in class lessons. Half of the course is devoted to lab work, where several microcontroller based systems of incremental complexity are implemented. A PIC16F676 from Microchip (Chandler, AZ) and the rFPICKit1 have been selected as lab tools.

A first lab assignment is a simple traffic light controller. The second assignment involves Analogue to Digital conversion from a LM35 temperature sensor. The aim of the third assignment is the connection of a LCD display to the PIC controller. Both ideas are integrated in the next assignment, in which a converted temperature is displayed in the screen. The last assignment consists in controlling a fan using a step motor through PWM according to the temperature of the room.

All lab work is carried out in assembler language, which students have already used in a previous course on microprocessor architecture. Although higher level languages are now commonly used for microcontroller programming, we think working directly with assembler is the best way to learn the architecture in detail.

Students are evaluated in situ in the laboratory and, in addition, they will hand in a final report of the laboratory work. Those with a good laboratory work can raise the exam mark up to one point. Thus, the final grade is given by the exam mark on top of which the laboratory mark is added (ranging from 0 to 1).

F. Electronic Systems and Circuis Design (ESCD)

The ESCD course [1] is a fourth year 6 credit compulsory course. The main objective of the course is to make students face the challenge of designing real digital electronic systems, showing the different design alternatives and their tradeoffs. As it can be observed in fig. 1, students taking this course have demonstrated their fundamental theoretical knowledge in digital design, computer architecture and analogue electronics. Thus, in this course we want students to learn the design

methodology in a practical way, assimilating the acquired knowledge in those courses and above all, that they face the real problems of digital electronic design and that they are able to solve them.

The contents of the course cover issues related to design methodology of complex circuits (modular design, reuse, testability, optimization), circuit interfacing and specific circuits, such as arithmetic circuits.

The course follows a PBL methodology. Rather than following a course based on the contents, we have decided to propose projects that introduce the students to those contents. Hence, during circuit design students face new challenges, and find the need to solve these problems. This raises their interest in the different solution methods.

The course has been structured in three kinds of classes: Seminars, guided laboratories and final project

Seminars are theoretical classes given throughout the semester. These seminars introduce the initial subjects and present each guided laboratory and the final project. These seminars summarize the problems that the students will face and the different approaches to tackle them. References are also included for further research.

The **guided laboratories** are the main learning method of the course. Students are faced with design projects of incremental complexity. The implementation of these projects leads the students to acquire the necessary experience to deal with the final project. Examples of these projects are the design of an UART, VGA controller, or a tennis videogame.

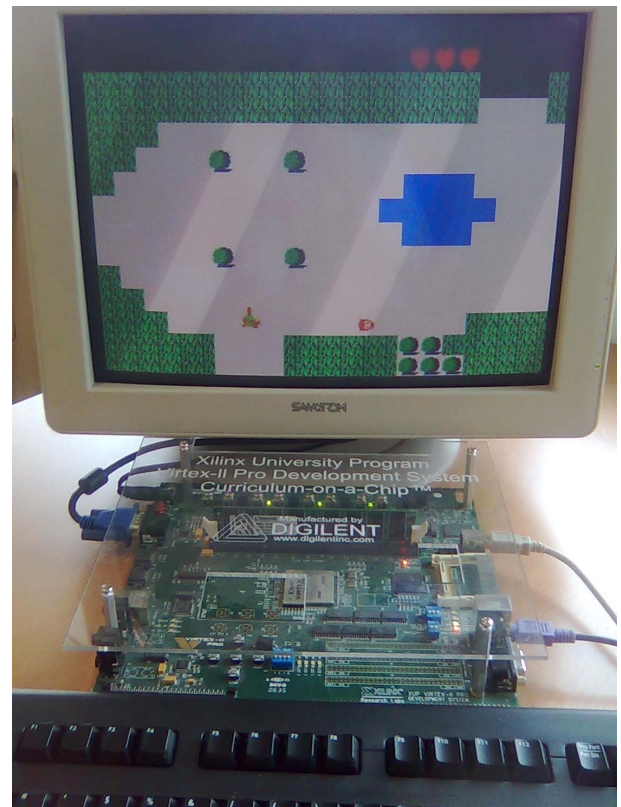

Figure 2: Snapshot of a videogame final DCSE project



Figure 3: Snapshot of a digital video final project

There is a continuous and formative assessment throughout the semester, in which alumni are provided with information on the adequacy and evolution of their work. Students are evaluated by their final project (70%) and theoretical exams (30%).

G. Electronic Instrumentation (EI)

The EI course is a fourth year 6 credit compulsory course. The fundamental concepts and methodologies of electronic instrumentation are covered in this course. The course has been structured in theoretical lectures, laboratories (1.5 credits), and two design projects.

The contents of the course cover issues that have not yet been studied, i.e., sensors, the design of signal conditioning circuits, an elementary introduction to signal transmission, several lectures on noise and interference and LabView (NI, Austin, TX) virtual instrumentation and data acquisition software.

The students carry out two types of lab work. In the first sessions, they use discrete components and two different experimental setups are proposed:

- Analysis and measurement of real operational amplifier parameters
- Design of the RTD sensor conditioning circuit.

During the final lab sessions, students learn about NI LabView environment and the basics of data acquisition. Finally, they will develop an analogue input tool based on the

RTD conditioning circuit designed in former sessions and on the NI USB-6009 Data Acquisition board.

On the other hand, students must hand in two design projects. The aim of these projects is to design a basic measurement system. Students should be able to understand the main specifications of a measuring system, select a specific sensor for an application, design conditioning circuits, connect sensors and actuators and integrate the measuring system to microcontroller-based systems. The design of a basic weather station capable of measuring the main meteorological variables: temperature, pressure, humidity, and wind speed is an example of a final project.

The final grade is given by the exam mark weighted by 0.8 plus the design project weighted by 0.2. A minimum of 4 over 10 points are needed in the exam mark to pass the course.

III. PROJECT BASED LEARNING AMONG DIFFERENT COURSES

We are currently carrying out voluntary lab works involving knowledge of different courses. In these labs, students of different courses jointly develop an electronic design. These labs follow a PBL methodology, in which the circuit specifications are given at the beginning and students have to find their own solution and build the circuit design. The projects have minimum goals, but proposals to enhance the project goals are provided, in case the students wish to continue developing it.

These labs are carried out during the first half of the course; therefore, the students perform them as they start with the contents given in their respective courses. This approach has the following “benefits” for the student:

- Students have the need to acquire the knowledge of the course prior to the exam and the compulsory labs.
- Students have investigated different solutions and have implemented the solution they think is more adequate.
- When the course contents are given during the compulsory classes and labs, students can compare their solution with other solutions.
- Students reinforce their knowledge when the contents are given during the classes and compulsory labs.

We have developed two kinds of projects:

- Horizontal projects
- Vertical projects

The horizontal projects involve students of the same year. For this kind of projects, the participants are students of Digital Electronics II (DE2) and Analogue Electronics (AE), both belonging to the first semester of the second year. These projects can be considered as horizontal in the sense that all students have the same level.

The vertical projects involve students of different years; therefore, the participants have different knowledge in electronics. These projects are considered as vertical since students of upper courses guide the other students. As a result,

some students have to coordinate the project and guide the others. As a consequence, the competences learned are wider than those learned in a same-year project.

Following, two of these projects will be described.

A. Electronic Piano Project

The electronic piano is a horizontal project carried out by students of Digital Electronics II (DE2) and Analogue Electronics (AE), both courses given during the second year.

The basic project consists in a digital square wave generator whose output is amplified to be heard through a small speaker. Fig. 4 shows the scheme of the basic electronic piano project. The digital part of the project is developed in a FPGA using VHDL and the output is amplified using analogue components.

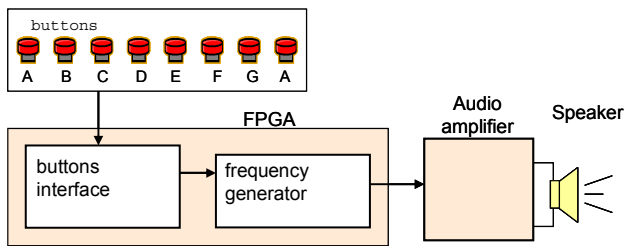

Figure 4: Basic electronic piano project

A minimum of eight frequencies have to be generated using one of the octaves. Table 1 shows some of the frequencies that could be used to generate the notes of an octave.

TABLE 1: FREQUENCIES OF THREE OCTAVES

Note Hz	A	B	C	D	E	F	G	A
	220.00	246.94	261.63	293.67	329.63	349.23	392.00	440.00
	440.00	493.88	523.25	587.33	659.26	698.46	783.99	880.00
	880.00	987.77	1046.5	1174.7	1318.5	1396.9	1568.0	1760.0

The audio amplifier has to be built considering the working frequencies. Fig. 5 shows the general scheme on an amplifier.

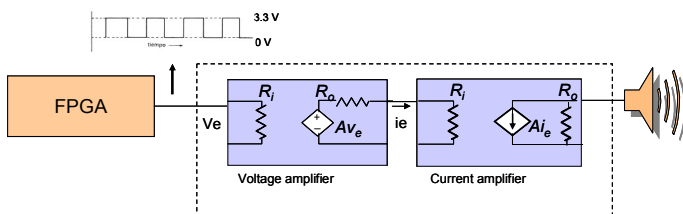

Figure 5: General scheme of an amplifier

Several considerations must be taken into account in order to design the audio amplifier. The output of the FPGA is a square signal with amplitude varying from 0 to 3.3 V; therefore, the output level is high enough to consider that the voltage amplifier stage of fig. 3 is not that critical. Loudspeakers introduce an 8 ohms load resistance and consume a power of 0.5 watts.

Finally, the amplifier bandwidth must be designed considering the frequency notes. In order to amplify the three octaves of table 1, low frequency should be one decade below 220 Hz. In this sense, external coupling capacitors should be carefully chosen. In the working frequency range, high frequencies pose no problems, since internal transistor capacitors introduce a cut off frequency well above 1760 Hz.

1) Electronic Piano Enhancements

The electronic piano can be enhanced in many ways. Some proposals are given to the students; nevertheless, they are free to propose any idea the like. The proposed enhancements are:

- Display the frequency or the note name through four seven-segment displays
- Instead of using the buttons or switches of the FPGA board, build a digital interface for a PS/2 keyboard.
- Build an analogue filter to modify the shape of the square wave
- Instead of generating a binary signal, generate an 8 bit digital signal with different shapes. Therefore, this signal has to be converted to analogue.
- Performing any other digital processing to the audio.

A scheme of the electronic piano project including some of the enhancement proposals is shown in fig. 6.

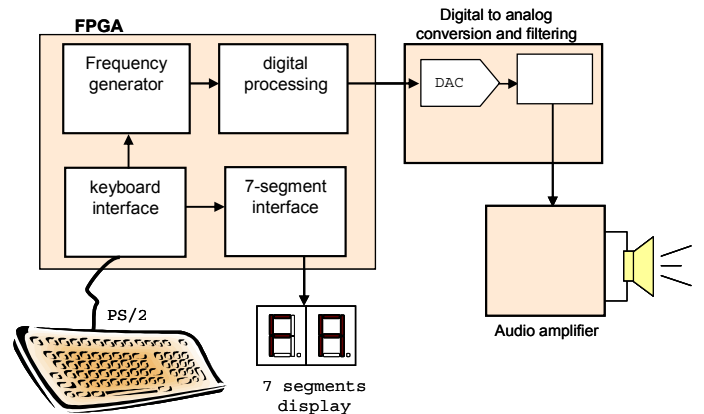

Figure 6: Proposals for the enhanced electronic piano project

B. Electrocardiogram Project

The electrocardiogram (ECG) project is a vertical project carried out by students of second (DE2), third (DES) and fourth years (ESCD and EI), see fig. 1. This project is more complex than the electronic piano project since it involves different technologies and requires a wider communication among the students, which, in addition, belong to different years.

As it has been stated, in these labs a basic project is first proposed to the students, but ideas are also given for possible enhancements.

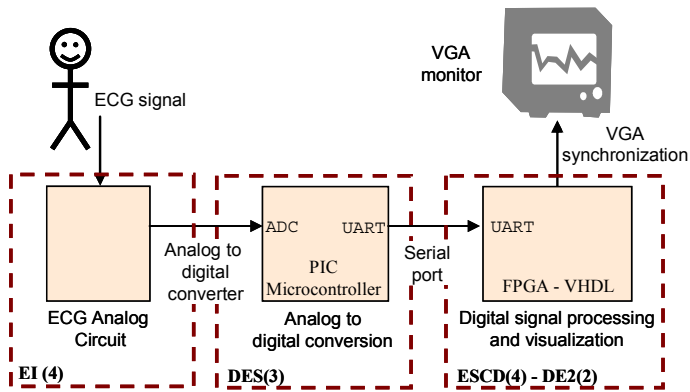

Figure 7: Basic ECG project

The basic project scheme is shown in fig. 7. In this scheme, the project has been separated in three blocks, corresponding to the different courses involved. These blocks are:

- ECG Analogue circuit: this block deals with the acquisition of the biological signal. It will be performed by students of Electronic Instrumentation (EI).
- Analogue to digital conversion: this block will convert the analogue signal into a digital signal. Students of Digital Electronic Systems will be responsible for building this block.
- Digital signal processing and visualization: this block will receive the digital signal from the PIC microcontroller and will show the ECG waveform in a VGA monitor. This block will be designed jointly by Digital Electronics II (DE2) and Electronic Systems and Circuits Design (ESCD) students.

The project has to be done in two stages because the course Electronic Instrumentation (EI) is taught during the second semester of the fourth year. Therefore, during the first stage, the students have to build the project considering that the analogue signal is already given (with an ECG emulator).

The project is coordinated by the students of ESCD. These students will assist the rest of the team helping them to define their block and the interfaces with the others. Later, in the second semester, ESCD students will finish the project building the ECG analogue circuit as part of their EI course.

As in the piano project, fig. 7 shows the basic implementation of the ECG project. Further enhancements are proposed as shown in fig. 8. These improvements include:

- Performing signal processing in the PIC microcontroller or in the FPGA.
- Showing the heart rate through a LCD or seven-segment display (using the PIC or the FPGA).
- Generate a sound every heart beat and amplify it with a analogue circuit. This enhancement would include students of AE, and would be similar to the electronic piano. The sound wave could also be generated by the PIC microcontroller.

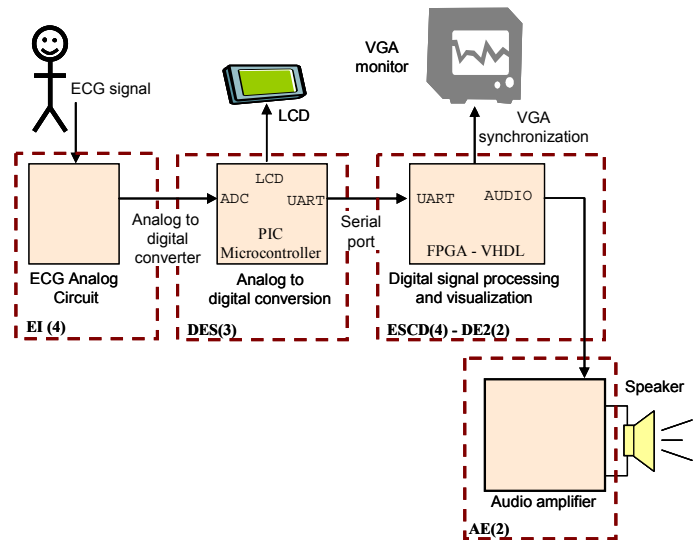

Figure 8: Enhanced ECG project

IV. RESULTS AND DISCUSSION

The proposed curriculum covers all aspects of analogue electronics (components, amplifiers, feedback, filtering, frequency analysis) with the ECM, AE and EI courses. Only some topics in communication electronics are not covered (PLLs, oscillators). Digital electronics is also thoroughly covered. Hardware description languages are covered in detail in DE1, DE2 and ESCD. Digital system design is taught through the DES and ESCD courses.

The curriculum has been evaluated taking into account the grades obtained by the students and their degree of satisfaction, as shown in official University surveys performed at the end of every course. Results show that students are highly satisfied with their training in electronics. Among the main topics pointed out in the survey we can highlight:

- Teaching methodology
- Course planning and organization
- Are the contents of the course interesting?

Table 2 shows the student evaluation of the electronic related courses described in section II. Scores range from 0 (lowest) to 5 (highest). The mean of each topic is above 4 out of 5.

TABLE 2: STUDENT EVALUATION OF THE COURSES

	ECM	DE1	DE2	AE	DES	ECDS	EI
A	4.1	4.0	4.0	3.5	4.1	4.5	3.6
B	3.9	4.0	3.9	3.8	4.2	4.2	3.8
C	4.0	4.4	4.4	3.8	4.3	4.6	3.7

Regarding PBL among courses, both horizontal and vertical projects were carried out as an experimental activity.

We have observed that horizontal activities are easier to perform, as students belong to the same group and have previous experience working together. Vertical activities

(integration of sub-project among student of different years) were harder to coordinate due to the different timetables, and degree of acquaintance. Around 15-20% of the students volunteered to participate in the special projects.

All horizontal activities were successfully accomplished in about four weeks, two weeks less than the time initially estimated. During that time, students worked mostly on their own, anticipating the concepts the professor explained in the regular lectures. Only in few occasions did they need the professor's advice. Additional skills inherent to the experimental work were acquired by the students, such as reading and comparing datasheet to meet project requirements and soldering in board. They even enhanced both by ideas proposed by the professors and by themselves. As an example, they proposed to store a melody in the FPGA. One of these projects is shown in fig. 9.

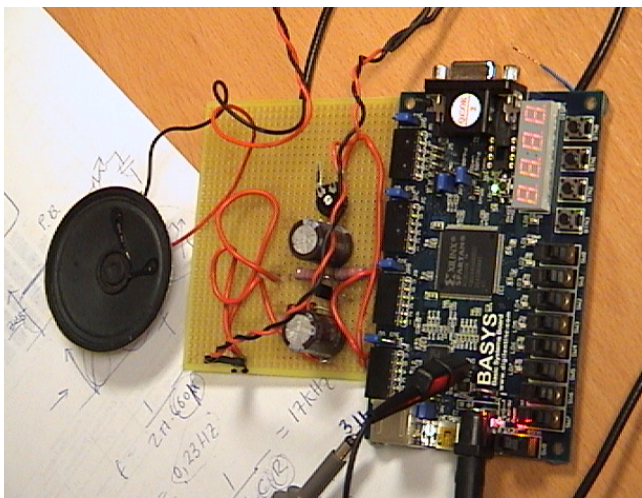

Figure 9: One of the resulting piano projects

Students that successfully completed the project, volunteered to present their work to the rest of the class. They prepared a fifteen minutes oral presentation and a live demo with the melodies stored in the FPGA. The response of the students that were not involved in the projects was of great enthusiasm, some of them expressing their will to join the project methodology next year.

In the vertical activities, two thirds of the groups completed their subproject, but they did not have enough time to integrate into the complete project. This was due to the difficulties in coordination among groups. However, all students intend to complete the integration along the next semester.

V. CONCLUSIONS

We have presented a project-oriented curriculum on Electronics for Telecommunication Engineers. These courses have been evaluated very positively by students. The consistent approach of this curriculum has allowed us to design project activities among different courses. This fact, together with the project orientation of each course, makes the transit to the Bologna Process easier.

The developed PBL activities among different courses have been received positively by the students. These projects provide students with skills and competences promoted by the Bologna Process, such as team work, initiative, responsibility and leadership. Participants have shown a high degree of motivation since many of the groups have finished before the assigned time and have performed many of the proposed enhancements.

REFERENCES

- [1] F. Machado, S. Borromeo, N. Malpica, "Project Based Learning Experience in VHDL Digital Electronic Circuit Design," Int. Conf. on Microelectronic Systems Education, USA, July 2009.
- [2] S. Borromeo, B. Romero, "Digital electronics teaching experience at Universidad Rey Juan Carlos based on development boards (*Experiencia docente de la enseñanza de la electrónica digital basada en tarjetas de desarrollo en la Universidad Rey Juan Carlos*)," Conf. de Tecnologías Aplicadas a la Enseñanza de la Electrónica, Spain 2006.
- [3] J. Macías-Guarasa, J. M. Montero, R. San-Segundo, A. Araujo, O. Nieto-Taladriz, "A project-based learning approach to design electronic system curricula," *IEEE Trans. Education*, 49(3) 2006.
- [4] J.L. Gonzalez-V., J.E. Loya-Hernandez, "Project-based learning of reconfigurable high density digital systems design: an interdisciplinary context based approach," *Frontiers in Education Conf.* USA, 2007
- [5] J. Northern "Project-based learning for a digital circuits design sequence" *IEEE Region. 5 Technical Conf.*, USA 2007
- [6] X. Pardo, M. Martín, J. Sanjurjo, C. Regueiro, "Teaching digital systems in the context of the new European higher education area: a practical experience," *IEEE Trans. Education*, 53(4) 2009
- [7] "ECTS Users' Guide," European Communities, Brussels, 2009