

# A Systems Theory Perspective of Electronics in Engineering Education

Manuel Castro and Rafael Sebastián

Electrical and Computer Department  
UNED - Spanish University for Distance Education  
Madrid, Spain  
mcastro@ieec.uned.es, rsebastian@ieec.uned.es

Jerónimo Quesada

MSc (Eng.) - Electronic Systems Engineering Consultant  
Tutor at UNED - Spanish University for Distance Education  
Teaching Fellow at University of the Basque Country  
j.quesada@computer.org

**Abstract**— We briefly review fundamental concepts related to systems theory and systems engineering. We also review and structure a list of important properties for an electronic system and paradigms and techniques applicable to analysis and design. Then we present two specific case studies, in which the systems theory approach to electronics engineering teaching and research has been very influential.

**Keywords:** *systems theory; systems engineering; electronics systems engineering; model-based systems engineering; requirements; requirement-driven engineering; validation; verification; systems engineering education; electronics engineering education*

## I. INTRODUCTION

Systems theory is an interdisciplinary and holistic approach to the study of complex structures and behaviors [1]. This theory is the main foundation of systems engineering, which on the one hand, is evolving as a specialized professional and academic discipline and, on the other hand, permeates other disciplines as a process and methodology. We present here a perspective of electronics engineering education and research from the systems theory and systems engineering approach.

We can identify two extreme approaches to systems engineering. The top-down approach followed by the professional who acts in the role of a pure systems engineer, without attachment to any specialized branch of engineering or technology; and the bottom-up of the specialist moving to a more general and system-level perspective. Both have advantages and disadvantages. One can argue that pure systems engineering specialization lacks a knowledge of details and of real capabilities of technology and solutions, and that the devil is in the details. The danger of the second is not seeing the forest for the trees. Here we propose a zooming approach to electronics systems engineering, shifting from the micro to the macro view and vice versa, as appropriate, and pointing out relationships, general properties and how they depend on decisions taken at every level. In reality, this process is applied in science when dealing with complex analysis or design issues, such as in medicine, where it is common to combine the microanalysis with the physiological, anatomical and environmental view in studies and diagnoses.

After this introduction we first present a summary of the process typically applied in systems engineering, consisting of iteration between requirement analysis, functional design and synthesis, with verification between steps, iteration, top-down decomposition, and validation of results against the perceived need and objectives.

Then we deal with enumeration and classification of the properties to be taken into account in an electronics system, as a basis for requirement analysis, and the applicable design and verification methods. The identification and structuring of requirements and properties is one of the open problems in systems engineering and, although theory and methodologies have been proposed, it relies mostly on the open-mindedness and creativity of the analyst.

Then we continue with the presentation of two case studies in which the systems perspective has contributed to a differential approach to electronics engineering education and research. We end with conclusions and proposals for future work.

Electronics systems are now prevalent in every field of human activity. They are often complex, with many interfaces and relationships. Failure of one of those systems can result in economic damage and even loss of human life. We think, therefore, that it is relevant to propose an integral and system-level approach to electronics systems engineering. That approach should also be incorporated in research and education, conveying ideas, perspectives and techniques to future professionals.

## II. SYSTEMS ENGINEERING

Systems engineering can be considered as a methodology or discipline in itself. Globe-spanning professional organizations such as INCOSE (National Council on Systems Engineering) and the IEEE Systems Council (a council formed by several IEEE societies) are promoting research, practice improvement and education in systems engineering.

### A. *Systems Engineering process*

An objective and differential characteristic of systems engineering is the exploration of alternatives and early adoption of critical design decisions. Several process schemas

for systems engineering have been proposed, such as the SIMILAR, by INCOSE [2]

We include here a simplified three-phase process (Fig. 1). This schema has to be run in iterative phases, verifying functionality against requirements, on the one hand, and design against functionality on the other. It is also applied in a hierarchical fashion following a top-down spatial decomposition of requirements, functionality and structure and applying the same cycle to every subsystem, module or component. This process has been assimilated to fractal geometry, with repetition of the process at different scales and not totally deterministic growth [3]. The results of the application are validated against perceived needs and objectives.

The main phases of the process can be summarized as follows:

- Identification, classification and contrast of requirements. A coherent, non-ambiguous and feasible set of requirements must be generated. Requirement definition is always a balance between capabilities and needs. This is a crucial step, as requirements provide the basis for performing all other key development activities such as system and component design, implementation, and testing.
- Functional design and behavior modeling. In this step it is important to think more about abstract functions that the system should perform, than about specific implementations. Functionality should be verified against requirements.
- Structural design, alternative selection, synthesis. Here, components, technologies and architectures are chosen to implement the functionality. The design has to be verified against functionality and behavior.

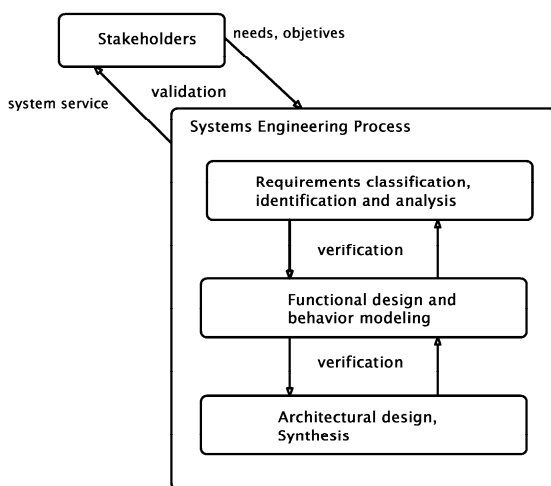

Figure 1. Systems engineering process

Model based systems engineering (MBSE) uses formal methods for modeling and analysis during the requirements, design, analysis and verification phases. A language oriented towards the modeling of complex systems and born as a subset of UML (Unified Modeling Language), with extensions, is SysML [5]. SysML includes diagrams for requirement, structure and behavior modeling, some of them common to UML.

### B. Properties and requirements

A “well-formed” requirement is a constraint imposed on a property of the system. In order to establish requirements, it is necessary to first consider all relevant properties of the system. It is usual in electronics engineering to take into account properties close to the technology, such as time and frequency response, maximum ratings, etc. The systems engineering approach implies that more general properties or characteristics should be considered when analyzing requirements. We try to convey a structured list of those we have found important in electronics systems analysis and design:

- Involving system dependability, that is, the confidence that the system will provide the intended service [6]: availability, safety, integrity, maintainability, confidentiality, etc.
- Involving the ease with which the system can be used, reconfigured, tested or debugged: usability, manageability, adaptability, modularity [10][11], composability [7][8], testability, traceability, etc.
- Involving predictability in the execution of the intended functionality: input-output response (value and time), determinism, operating modes, graceful degradation, etc.
- Involving energy, power, and compatibility with the environment: power feeding, power efficiency, power and thermal management, power density, electromagnetic compatibility (EMC), etc.
- Economics: overall life cycle cost, cost of ownership, return on investment (ROI), etc.
- ...

In the design, which can include hardware, software, communications, sensors, actuators, and so on, the application of some paradigms and techniques can be considered, such as:

- Partitioning and distribution of functions, redundancy, replica determinism [9][42], etc.
- Distributed control and management, fault tolerance, real time scheduling, concurrency, etc.
- Computational models, hard-soft decomposition, programming paradigms, etc.
- ...

Rigorous specification, verification and validation could demand the application of formal methods, modeling and simulation languages [4], RMA (reliability, maintainability, availability) analysis, etc.

Modeling and simulation is the preferred verification method before physical design. Electronics engineers have traditionally made use of simulation and modeling tools, based on hardware description languages (SPICE, VHDL, VHDL-AMS or Verilog) and even, more recently, hardware-software codesign-oriented languages (such as SystemC). Tools capable of multi-domain continuous, discrete and hybrid system simulation and modeling are very valuable for systems in which electronics is combined with other technologies. Modeling and simulation based on other computation models, such as the discrete event or finite state machines, are also often necessary.

### III. CASE STUDY I. A POSTGRADUATE COURSE IN MODELLING AND CONTROL OF INVERTERS

Inverters or DC-AC power converters are widely used in uninterrupted power systems [19], renewable energy integration and distributed generation [41]. The expansion of renewable energy in the last few decades has heightened interest in inverter control techniques, both as autonomous generators (in a UPS, for example) and as a feeder connected to the electrical grid (in a PV solar farm, for example)

We try to describe here how the systems approach has influenced our research and teaching in this specific area. More specifically, what the impact has been on a recent proposal for a short postgraduate course in inverter modeling and control. It is not an objective to describe the proposal itself, but only to explain how systems theory, and systems engineering, has influenced its approach and development. Most of the decisions and orientations were adopted as a result of the requirements analysis phase.

Considerations related to high availability, a fundamental requirement for UPS, had an important influence. High availability means that redundancy has to be applied, which drove us to consider aspects related to modular decomposition.

In fact, most modern UPS are modular, based on a set of easily replaceable modules working in parallel. A modular architecture brings additional advantages such as flexibility in expansion, adding power as needs evolve.

Paralleling modules implies that they must work in tight synchronization and share load. Parallel inverter control has been and continues to be a subject of constant research [12][13][14][15][16]. We are dealing with this problem as part of a study in the distributed, fault-tolerant, real-time control of modular electronics systems.

The combination of modular power converters can be approached from a more general point of view, with application of bond graph modeling techniques [18] (Fig. 2). This approach emphasizes analogies between different types of power converters, such as an inverter or a controlled motor. It is a typical example of the generalization process applied in systems theory.

When an inverter works as an autonomous generator, the analysis cannot disregard one of the most important requirements: disturbance rejection capability (Fig. 3), or the ability to maintain wave quality under distorting or varying load. That is, low total harmonic distortion (THD). UPS applicable standards impose limits and establish test procedures [20]. This requirement had a decisive influence in the selection of the modeling and control techniques applied.

We propose a model for a controlled inverter that establishes a clear distinction between modulation and control (Fig. 4). This is a typical decomposition result of the application of a functional analysis phase. Pulse width modulation, or space vector modulation for a three-phase inverter, is studied independently of control [21]. The modulator only affects control through the actuation delay, which it can add to the loop, especially when regular modulation is applied [22].

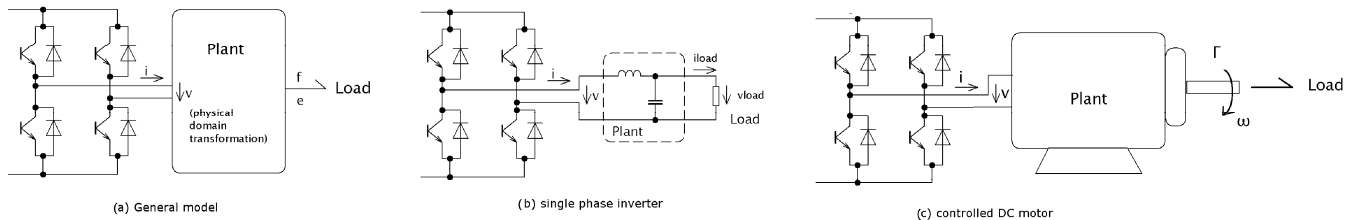

Figure 2. Bond graph models: generic, inverter and controlled motor

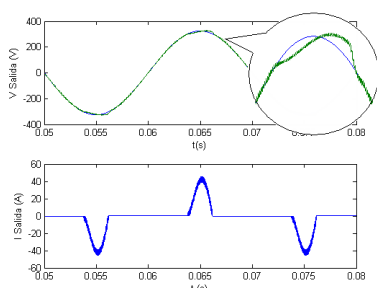

Figure 3. Inverter output under distorting load

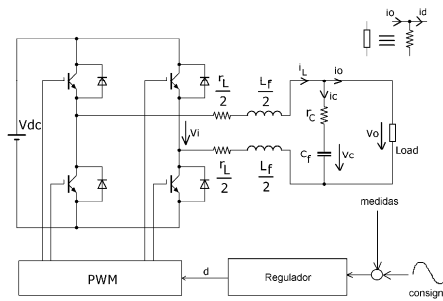

Figure 4. Single phase inverter model

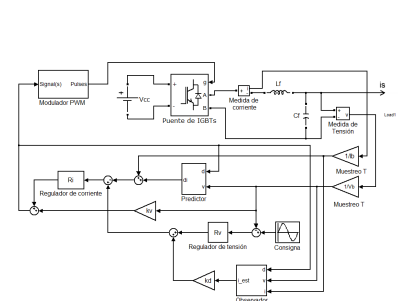

Figure 5. Digital controller model

The control technique applied determines set point following and disturbance rejection capacity, that is, output impedance [23][29]. We propose continuous and discretized state space models of the controlled inverter, which are then used as a basis for controller design [25][26]. Even the design of the controlled plant itself (the LC output filter [24]) is based on control requirements. We signal the importance of current control, in an internal loop, to yield quick dynamics and good disturbance rejection capability.

In a typical application of MBSE concepts, we decide to propose a reference controller, with the best possible performance: of continuous type, based on feed forward of output current, natural modulation etc. Against this reference controller others are contrasted and evaluated, such as digital controllers (Fig. 5) that can be implemented over microcontrollers or digital signal processors [17], and based on predictive current control and output current observer [27][28][29][30][31][32][33][34][35].

As a modeling, simulation and analysis tool we use the Matlab-Simulink suite, R2008b version, applying the Control System and Symbolic Math toolboxes, and the SimPowerSystems Blockset.

An exhaustive analysis of control requirements drove us towards the need of taking into account control related aspects such as reference sine wave generation. Synchronization of this reference with other modules or with the grid should be taken into account, and the applicable techniques studied [36][37]. The load sharing problem, with synchronization and without degradation of availability, motivated the research of classical techniques, such as the droop method, and other possibilities based on communication between modules and replica determinism.

A broad consideration of inverter applications includes the consideration of its integration in different kinds of electrical grids, in grid-feeding, grid-creation or grid-support mode [38][40] (Fig. 6). The modeling, simulation and control techniques are completely different from those applied for the inverter itself. We model the inverter as a voltage or current source and apply time-varying phasor modeling techniques [39].

The “zoom” view previously mentioned is applied in the lectures. The different control time scales, from the internal to that applied in grid integration, are contrasted. In the requirement, functionality and architecture analysis of the internal inverter, characteristics are associated with integration of inverters in modular systems on in electrical grids or microgrids.

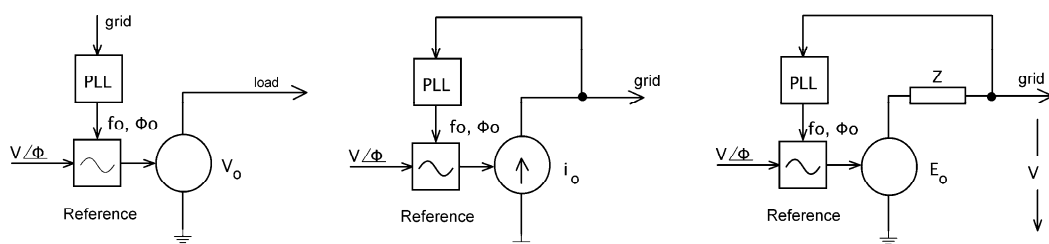

Figure 6. Grid forming, grid feeding and grid supporting inverters

#### IV. CASE STUDY II. TEACHING ELECTRONICS IN A SECOND CYCLE CURRICULUM IN INDUSTRIAL ORGANIZATION.

In 2001 J.Q. started teaching Industrial Electronics as a subject in a second cycle curriculum in industrial organization, at the University of the Basque Country (UPV-EHU), Spain. The subject involves 30 lecture hours and an additional 15 laboratory hours. In a trimester, general, analog, digital and power electronics have to be taught to non-specialist graduate students, most of whom have no previous exposure to electronics. The course is geared toward graduate students with a technical engineering degree in chemistry, computer science or mechanics, for example. The most important concern was having a syllabus that was too scattered and blurred, difficult to understand and assimilate, in the short period allocated to the subject.

The syllabus was gradually refined over each of the several courses taught, and is now divided as follows:

- Introduction to industrial electronics: review of electrical circuits, basics of semiconductors, P-N junction, devices (BJT, MOSFET, Thyristor, IGBT). The different physical scales and ranges of application are reviewed, from micro-integration to power discrete devices (6 h. approx.).
- Analog electronics. A general and abstract approach is used to review the most relevant properties, characteristics and requirements: gain, feedback, linearity, frequency response, differential amplification and common mode rejection. At a more concrete level the operational amplifier and the most basic circuits are presented (4 h. approx.).
- Digital electronics. We review the basics of digital electronics, and then schematize combinational and sequential digital systems, paying special attention to fundamentals and examples of specific circuits. The objective is to give the students the foundation to understand the basics of microprocessors. Then we use a simple microcontroller model to convey the principles of programmable digital systems, including input-output and digital to analog and analog to digital conversion (8 h).
- Power electronics. A generic and abstract model of a power converter, including control, is presented. Specific models, such as diode rectifiers, thyristor controlled rectifiers, and switching DC-DC and DC-AC converters are briefly studied. We note differences and analogies in control and highlight basic concepts such as static and dynamic losses, efficiency etc. (8 h).

Laboratory classes are partly devoted to practice with circuits and instrumentation, and partly to exercises and discussions. At the end of the trimester we study a relevant integral example. The few students with a previous background in electronics collaborate in the proposal and development of the example. The “zoom” technique is applied here to review characteristics, and the basics of the systems engineering approach are used to study requirements and associated functionality. Some examples of systems: a PV solar farm, a multiple lift system for an intelligent building, automotive electronics etc. (4 h)

We constantly strive to keep the system view in mind, using analogies to medicine and the human body: cells and tissues for devices, senses for analog electronics, the brain and nervous system for digital electronics and the locomotor system for power electronics. And we prioritize the requirement and functional analysis over implementation, although implementation limitations are taken into account to illustrate the need for a feasible requirement proposal for the systems.

Grading is fundamentally based on a final exam, based on questions and very short exercises. The overall experience has been very positive; more than 300 students have attended the course since 2001 with high average results and positive feedback in student opinion polls.

## V. CONCLUSIONS AND FUTURE WORK

Modern electronics engineering has to deal with complex and critical projects and ample diversity of techniques and technologies [42]. Complex requirements have to be met, time to market reduced, and it is necessary to deal with limited budgets and design to cost constraints. Electronic systems must often be assembled from COTS (Commercial Off The Shelf) electronic subsystems and components, which may be manufactured half way around the world, and for which the most important task is to prescribe and verify characteristics against requirements. The systemic approach is a powerful tool to tackle with these demanding challenges. We think it should be included in academic curricula and applied in research and education.

Future research will focus on analyzing the possibility of using Case Study I as the basis for developing an educational example of MBSE, with application of the SysML language and perhaps other modelling tools, following a detailed systems engineering process.

Case study II can be the basis for the proposal to include a systems engineering subject in curricula [43]. INCOSE maintains a directory of systems engineering academic programs[44]. There are no Spanish programs included in the directory as of the writing of this paper.

## ACKNOWLEDGMENT

J. Q. has maintained fruitful and interesting discussions in systems engineering related forums and wished to thank all of the professionals involved in those discussions.

## REFERENCES

- [1] Ludwig von Bertalanffy. *General System Theory: Foundations, Development, Applications*. 1968.
- [2] A. Terry Bahill, Frank F. Dean "What Is Systems Engineering? A Consensus of Senior Systems Engineers" maintained at <http://www.sie.arizona.edu/sysengr/whatis/whatis.html> (30 Oct 2009)
- [3] Hall, A.D., III, "The fractal architecture of the systems engineering method," *IEEE Transactions on Systems, Man, and Cybernetics, Part C: Applications and Reviews*, , vol.28, no.4, pp.565-572, Nov 1998
- [4] Ören, T.I. and L. Yilmaz. "Synergy of Systems Engineering and Modeling and Simulation". *Proceedings of the 2006 International Conference on Modeling and Simulation - Methodology, Tools, Software Applications (M&S MTSA)*, July 31 - August 2, 2006, Calgary, AL, Canada, pp. 10-17.
- [5] Object Management Group (OMG). "Systems Modeling Language (SysML) Specification. Version 1.1", April 2006.
- [6] Avizienis, A.; Laprie, J.-C.; Randell, B.; Landwehr, C., "Basic concepts and taxonomy of dependable and secure computing," *Dependable and Secure Computing, IEEE Transactions on*, vol.1, no.1, pp. 11-33, Jan.-March 2004
- [7] H. Kopetz, G. Bauer "The time-triggered architecture", *Proceedings of the IEEE*, Volume 91, Issue 1, Jan. 2003 Page(s):112 – 126
- [8] Kopetz, H. and N. Suri. "Compositional Design of Real- Time System: A Conceptual Basis for the Specification of Linking Interfaces". in *ISORC 2003--The 6th International Symposium on Object Oriented Real-Time Computing*. 2003.
- [9] Stefan Poledna, *Fault-Tolerant Real-Time Systems: The Problem of Replica Determinism*, Kluwer Academic Publishers, Norwell, MA, 1996
- [10] H. Chun-Che; A. Kusiak "Modularity in design of products and systems," *IEEE Transactions on Systems, Man and Cybernetics, Part A: Systems and Humans*, , vol.28, no.1, pp.66-77, Jan 1998
- [11] F. Salvador, "Toward a Product System Modularity Construct: Literature Review and Reconceptualization", *IEEE Transactions on Engineering Management*, Volume 54, Issue 2, Date: May 2007, Pages: 219 – 240
- [12] Chandorkar, M.C.; Divan, D.M.; Adapa, R.; "Control of parallel connected inverters in standalone AC supply systems"; 1993, *IEEE Transactions on Industry Applications*. 1993
- [13] Jiann-Fuh Chen; Ching-Lung Chu; "Combination voltage-controlled and current-controlled PWM inverters for UPS parallel operation"; 1995, *IEEE Transactions on Power Electronics*, Volume: 10 , Issue: 5, pp 547 – 558
- [14] Holtz, J.; Werner, K.-H.; "Multi-inverter UPS system with redundant load sharing control"; 1990, *IEEE Transactions on Industrial Electronics*, Volume 37, Issue 6, pp 506 - 513
- [15] J. M. Guerrero, J. Matas, L. Garcia de Vicuna, M. Castilla, J. Miret. "Decentralized Control for Parallel Operation of Distributed Generation Inverters Using Resistive Output Impedance". 2007, *IEEE Transactions on Industrial Electronics*, pp 994-100
- [16] J. M. Guerrero; L. GarcíadeVicuna; J. Matas, M. Castilla, J. Miret. "Output Impedance Design of Parallel-Connected UPS Inverters With Wireless Load-Sharing Control". *IEEE Transactions on Industrial Electronics*, , vol.52, no.4, pp. 1126-1135, Aug. 2005
- [17] Y. Ito, S. Kawauchi. "Microprocessor-Based Robust Digital Control for UPS with Three-Phase PWM Inverter". *IEEE Transactions on Power Electronics* Vol. 10, No 2, March 1995.
- [18] P.J. Gawthrop, G.P. Bevan. *Bond-graph modeling*. *Control Systems Magazine*, IEEE Vol. 27, No 2, April 2007.
- [19] J.M.Guerrero, L. Garcia de Vicuna, J. Uceda. "Uninterruptible power supply systems provide protection". *IEEE Industrial Electronics Magazine*, 2007.
- [20] Norma IEC 62040-3:1999 Uninterruptible power systems (UPS) –Part 3: Method of specifying the performance and test requirements, 1999, CEI/IEC
- [21] D. Grahame and T. A. Lipo. "Pulse width modulation for power converters: principles and practice". 2003, John Wiley. ISBN: 0471208140.

- [22] Van de Syde, D.M.; De Gussemé, K.; Van den Bossche, A.P.; Melkebeek, J.A.. "Small-signal Laplace-domain analysis of uniformly-sampled pulse-width modulators". IEEE 35th Annual Power Electronics Specialists Conference PESC 04.
- [23] G. C. Goodwin, S. F. Graebe, M. E. Salgado. Control System Design. 2001, Prentice Hall
- [24] P.A. Dahono, A. Purwadi, Qamaruzzaman. "An LC filter design method for single-phase PWM inverters". Proceedings of 1995 International Conference on Power Electronics and Drive Systems, pp.571-576 vol.2, 21-24 Feb 1995.
- [25] J. Sun, D. M. Mitchell, F. Greuel, P. T. Krein, and R. M. Bass. "Averaged Modeling of PWM Converters Operating in Discontinuous Conduction Mode". IEEE Transactions on Power Electronics, Vol. 16, No. 4, 2001, pp. 482-492
- [26] J. Sun and H. Grotstollen. "Averaged modeling of switching power converters: reformulation and theoretical basis". in Proc. IEEE PESC'92, 1992, pp. 1166-1172.
- [27] D.G.Holmes,D.A. Martin. "Implementation of a direct digital predictive current controller for single and three phase voltage source inverters". Conference Record of the 1996 IEEE Industry Applications Conference, 1996.
- [28] S. Buso, S. Fasolo, P. Mattavelli. "Uninterruptible power supply multiloop control employing digital predictive voltage and current regulators". 2001, IEEE Transactions on Industry Applications
- [29] Ryan, M.J.; Brumsickle, W.E.; Lorenz, R.D. "Control topology options for single-phase UPS inverters". 1997, IEEE Transactions on Industry Applications, vol 33.
- [30] N. M. Abdel-Rahim, J.E. Quaicoe. "Analysis and design of a multiple feedback loop control strategy for single-phase voltage-source UPS inverters". 1996, IEEE Transactions on Power Electronics, Vol 11.
- [31] Heng Deng; R. Oruganti, D. Srinivasan. "Modeling and Control of Single-Phase UPS Inverters: A Survey". 2005, International Conference on Power Electronics and Drives Systems, 2005. PEDS 2005
- [32] A. Kawamura, T. Yokoyama. "Comparison of five different approaches for real time digital feedback control of PWM inverters". Conference Record of the 1990 IEEE Industry Applications Society Annual Meeting
- [33] Poh Chiang Loh; M.J. Newman, D.N. Zmood, D.G. Holmes. "A comparative analysis of multiloop voltage regulation strategies for single and three-phase UPS systems". 2003, IEEE Transactions on Power Electronics, Vo 18
- [34] C. Rech, H.A. Grundling, J.R. Pinheiro. "Comparison of discrete control techniques for UPS applications". 2000, Conference Record of the 2000 IEEE Industry Applications Society Annual Meeting
- [35] P. Mattavelli. "An improved deadbeat control for UPS using disturbance observers". IEEE Transactions on Industrial Electronics, vol.52
- [36] B.P. McGrath, D.G. Holmes, J.J.H. Galloway. "Power converter line synchronization using a discrete Fourier transform (DFT) based on a variable sample rate". IEEE Transactions on Power Electronics, vol.20, no.4, pp. 877-884, July 2005
- [37] A. Timbus, R. Teodorescu, F. Blaabjerg, M. Liserre. "Synchronization Methods for Three Phase Distributed Power Generation Systems. An Overview and Evaluation". Power Electronics Specialists Conference, 2005. PESC '05. IEEE 36th.
- [38] K. De Brabandere. "Voltage and frequency droop control in low voltage grids by distributed generators with inverter front-end". PhD. Thesis, Universidad Católica de Lovaina, ISBN 90-5682-745-6, October, 2006
- [39] V. Venkatasubramanian, H. Schattler, J. Zaborszky. Fast time-varying phasor analysis in the balanced three-phase large electric power system. IEEE Transactions on Automatic Control, vol.40, no.11, pp.1975-1982, Nov 1995
- [40] K. De Brabandere, B. Bolsens, J. Van den Keybus, A. Woyte, J. Driesen, and R. Belmans. "A voltage and frequency droop control method for parallel inverters". IEEE Transactions on Power Electronics, vol.22, no.4, pp.1107-1115, Julio 2007.
- [41] R. Sebastian, J. Quesada. "Distributed control system for frequency control in a isolated wind system". Renewable Energy, 2006, 31 (3), pp. 285-305.
- [42] Kopetz, H., "The Complexity Challenge in Embedded System Design," 2008 11th IEEE International Symposium on Object Oriented Real-Time Distributed Computing (ISORC), , vol., no., pp.3-12, 5-7 May 2008
- [43] Asbjornsen, O.A.; Hamann, R.J., "Toward a unified systems engineering education," IEEE Transactions on Systems, Man, and Cybernetics, Part C: Applications and Reviews, vol.30, no.2, pp.175-182, May 2000
- [44] INCOSE . Directory of systems engineering academic programs. <http://www.incose.org/educationcareers/academicprogramdirectory.aspx> (30 Oct 2009)